

# NX-Series Power Supply Unit

# NX-PA/PD

CSM\_NX-PA\_PD\_DS\_E\_2\_1

## Powerful power supply unit to supply stable power to the NX-series controller.

Stable power supply is available from the NX-series CPU Unit to each I/O Unit via the dedicated bus. Lineups are provided for AC input types with 90 W output and DC input types with 70 W output.



NX-PD7001

## Features

- AC input types with 90 W output or DC input types with 70 W output allows power supply to large-scale configurations.
- Operating output contact indicates the CPU operation status (available in all models).

## Ordering Information

### International Standards

- The standards are abbreviated as follows: U: UL, U1: UL(Class I Division 2 Products for Hazardous Locations), C: CSA, UC: cULus, UC1: cULus (Class I Division 2 Products for Hazardous Locations), CU: cUL, N: NK, L: Lloyd, CE: EC Directives, C-Tick: C-Tick mark, and KC: KC Registration.
- Contact your OMRON representative for further details and applicable conditions for these standards.

## Power Supply Units

Product Name	Power supply voltage	Output capacity	Options			Model	Standards
		Total power consumption	24-VDC service power supply	RUN output	Maintenance forecast monitor		
AC Power Supply Unit	100 to 240 VAC	90 W	No	Yes	No	NX-PA9001	UC1, N, CE, RCM, KC
DC Power Supply Unit	24 VDC	70 W				NX-PD7001	

## Accessories

There is no accessory for the NX-series Power Supply Unit.

Sysmac is a trademark or registered trademark of OMRON Corporation in Japan and other countries for OMRON factory automation products. Other company names and product names in this document are the trademarks or registered trademarks of their respective companies.

## General Specification

Item	Specifications	
<b>Model</b>	NX-PA9001	NX-PD7001
<b>Dimensions</b>	80 × 100 × 100 mm (W × H × D)	51 × 100 × 100 mm (W × H × D)
<b>Weight</b>	570 g	290 g
<b>Power supply voltage</b>	100 to 240 VAC (wide-range), 50/60 Hz (85 to 264 VAC, 47 to 63 Hz)	24 VDC (20.4 to 28.8 VDC)
<b>Power consumption</b>	150 VA max.	85 W max.
<b>Inrush current *1</b>	At 100 VAC: 20 A *2/8 ms max. for cold start at room temperature At 200 VAC: 40 A *2/8 ms max. for cold start at room temperature	At 24 VDC: 30 A/2 ms max. for cold start at room temperature 7 A *3/3 s max. for cold start at room temperature
<b>Output capacity *4</b>	Total: 90 W max.	Total: 70 W max.
<b>Output terminal (service supply)</b>	Not provided.	
<b>RUN Output</b>	Contact configuration: SPST-NO Switch capacity: 250 VAC, 2 A (resistive load) 120 VAC, 0.5 A (inductive load), 24 VDC, 2A (resistive load)	
<b>Replacement notification function</b>	Not provided.	
<b>Insulation resistance</b>	20 MΩ min. (at 500 VDC) between AC external and GR terminals *5	--- *6
<b>Dielectric strength</b>	2,300 VAC 50/60 Hz for 1 min between AC external and GR terminals *5 *7 Leakage current: 5 mA max.	--- *6

- \*1. The inrush current may vary depending on the operating condition and other conditions. Therefore, select fuses, breakers, and external power supply devices that have enough margin in characteristic and capacity, considering the condition under which the devices are used.
- \*2. If the ambient temperature is higher or the Controller is hot-started, the inrush current given in the table may be exceeded by up to twice the given value because the thermistor element with a low-temperature current control characteristic is not sufficiently cool.
- \*3. Of the inrush current values, the latter value varies depending on the input voltage and may rise to approx. 8.3 A at 20.4 VDC.
- \*4. Internal components in the Power Supply Unit will deteriorate or be damaged if the Power Supply Unit is used for an extended period of time exceeding the power supply output capacity or if the outputs are shorted.
- \*5. Apply the voltage between the Power Supply Unit's L1 or L2 terminal and the GR terminal when testing insulation and dielectric strength. The tests can also be performed with the LG terminal and GR terminal connected to each other. In this case, the leakage current will be 10 mA or less.
- \*6. The primary DC power supply and the secondary DC power supply are not isolated.
- \*7. Change the applied voltage gradually using the adjuster on the Tester. If the full dielectric strength voltage is applied or turned OFF using the switch on the Tester, the generated impulse voltage may damage the Power Supply Unit.

# External Interface

## NX-PA9001

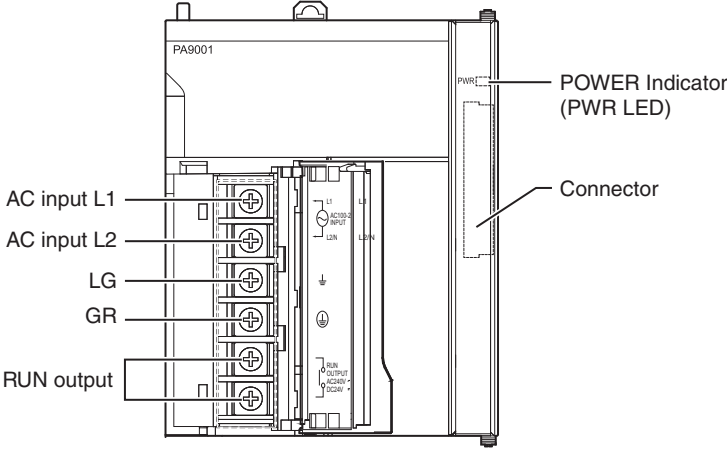

## NX-PD7001

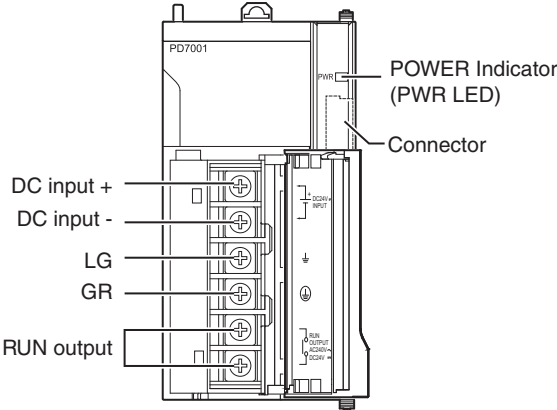

### AC Input

Supply 100 to 240 VAC (allowable: 85 to 264 VAC).  
The NX-PA9001 has a wide input range, so it does not have voltage switching terminals.

### DC Input

Supply 24 VDC (allowable: 20.4 to 28.8 VDC.)

### LG

Ground to a resistance of 100 Ω or less to increase noise resistance and avoid electric shock.

### GR

Ground to a resistance of 100 Ω or less to avoid electric shock.

### RUN Output

The internal contacts for the RUN output turn ON when the CPU Unit is in RUN status.

## Wiring

### ●About Power Supply

For AC/DC power supply

Recommended wire diameter	AWG 14 to 20 (Cross section 0.517 to 2.08 mm <sup>2</sup> )
---------------------------	--

For grounding wire

Recommended wire diameter	2 mm <sup>2</sup> or thicker
---------------------------	------------------------------

### ●Crimp Terminals

The terminals on the Power Supply Unit are M4, self-raising terminals with screws.

Crimp Terminals for AC Power Supplies



Crimp Terminals for DC Power Supplies

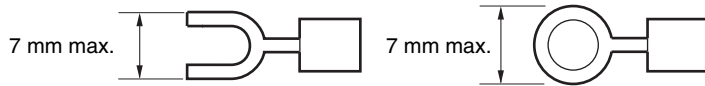

Crimp terminal for the grounding wire

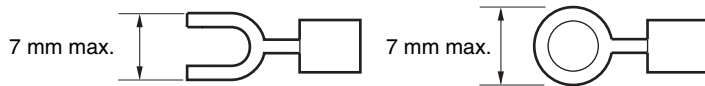

## Precautions for Use

### Compatible CPU Models

NX-PA9001/NX-PD7001 are dedicated for NX-series.

# Dimensions

## NX-PA9001

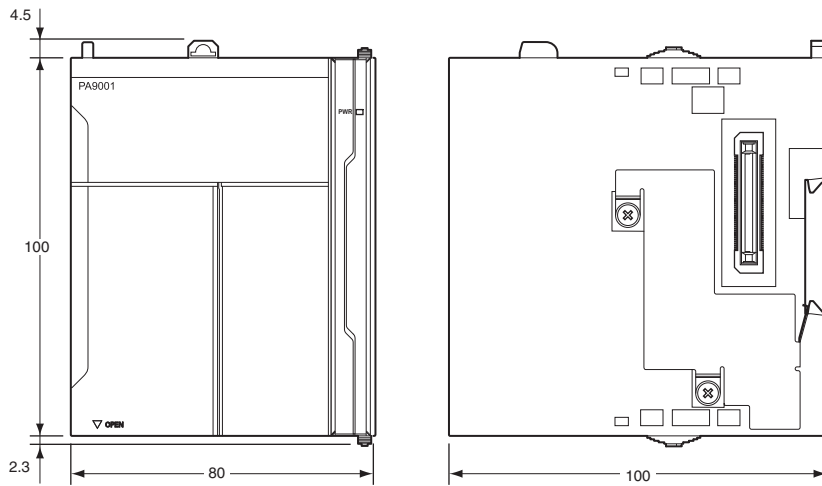

## NX-PD7001

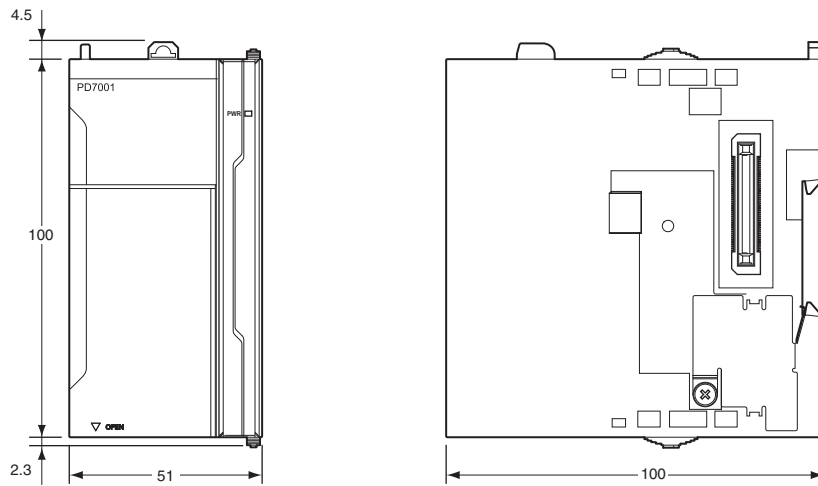

# Related Manuals

Manual name	Cat. No.	Model numbers	Application	Description
NX-series CPU Unit Hardware User's Manual	W535	NX701-□□□□	Learning the basic specifications of the NX-series CPU Units, including introductory information, designing, installation, and maintenance. Mainly hardware information is provided.	An introduction to the entire NX-series system is provided along with the following information on a Controller built with a CPU Unit. <ul style="list-style-type: none"> <li>• Features and system configuration</li> <li>• Introduction</li> <li>• Part names and functions</li> <li>• General specifications</li> <li>• Installation and wiring</li> <li>• Maintenance and inspection</li> </ul> Use this manual together with the <i>NJ/NX-series CPU Unit Software User's Manual</i> (Cat. No. W501).

## Terms and Conditions Agreement

### Read and understand this catalog.

Please read and understand this catalog before purchasing the products. Please consult your OMRON representative if you have any questions or comments.

### Warranties.

(a) Exclusive Warranty. Omron's exclusive warranty is that the Products will be free from defects in materials and workmanship for a period of twelve months from the date of sale by Omron (or such other period expressed in writing by Omron). Omron disclaims all other warranties, express or implied.

(b) Limitations. OMRON MAKES NO WARRANTY OR REPRESENTATION, EXPRESS OR IMPLIED, ABOUT NON-INFRINGEMENT, MERCHANTABILITY OR FITNESS FOR A PARTICULAR PURPOSE OF THE PRODUCTS. BUYER ACKNOWLEDGES THAT IT ALONE HAS DETERMINED THAT THE PRODUCTS WILL SUITABLY MEET THE REQUIREMENTS OF THEIR INTENDED USE.

Omron further disclaims all warranties and responsibility of any type for claims or expenses based on infringement by the Products or otherwise of any intellectual property right. (c) Buyer Remedy. Omron's sole obligation hereunder shall be, at Omron's election, to (i) replace (in the form originally shipped with Buyer responsible for labor charges for removal or replacement thereof) the non-complying Product, (ii) repair the non-complying Product, or (iii) repay or credit Buyer an amount equal to the purchase price of the non-complying Product; provided that in no event shall Omron be responsible for warranty, repair, indemnity or any other claims or expenses regarding the Products unless Omron's analysis confirms that the Products were properly handled, stored, installed and maintained and not subject to contamination, abuse, misuse or inappropriate modification. Return of any Products by Buyer must be approved in writing by Omron before shipment. Omron Companies shall not be liable for the suitability or unsuitability or the results from the use of Products in combination with any electrical or electronic components, circuits, system assemblies or any other materials or substances or environments. Any advice, recommendations or information given orally or in writing, are not to be construed as an amendment or addition to the above warranty.

See <http://www.omron.com/global/> or contact your Omron representative for published information.

### Limitation on Liability; Etc.

OMRON COMPANIES SHALL NOT BE LIABLE FOR SPECIAL, INDIRECT, INCIDENTAL, OR CONSEQUENTIAL DAMAGES, LOSS OF PROFITS OR PRODUCTION OR COMMERCIAL LOSS IN ANY WAY CONNECTED WITH THE PRODUCTS, WHETHER SUCH CLAIM IS BASED IN CONTRACT, WARRANTY, NEGLIGENCE OR STRICT LIABILITY.

Further, in no event shall liability of Omron Companies exceed the individual price of the Product on which liability is asserted.

### Suitability of Use.

Omron Companies shall not be responsible for conformity with any standards, codes or regulations which apply to the combination of the Product in the Buyer's application or use of the Product. At Buyer's request, Omron will provide applicable third party certification documents identifying ratings and limitations of use which apply to the Product. This information by itself is not sufficient for a complete determination of the suitability of the Product in combination with the end product, machine, system, or other application or use. Buyer shall be solely responsible for determining appropriateness of the particular Product with respect to Buyer's application, product or system. Buyer shall take application responsibility in all cases.

NEVER USE THE PRODUCT FOR AN APPLICATION INVOLVING SERIOUS RISK TO LIFE OR PROPERTY OR IN LARGE QUANTITIES WITHOUT ENSURING THAT THE SYSTEM AS A WHOLE HAS BEEN DESIGNED TO ADDRESS THE RISKS, AND THAT THE OMRON PRODUCT(S) IS PROPERLY RATED AND INSTALLED FOR THE INTENDED USE WITHIN THE OVERALL EQUIPMENT OR SYSTEM.

### Programmable Products.

Omron Companies shall not be responsible for the user's programming of a programmable Product, or any consequence thereof.

### Performance Data.

Data presented in Omron Company websites, catalogs and other materials is provided as a guide for the user in determining suitability and does not constitute a warranty. It may represent the result of Omron's test conditions, and the user must correlate it to actual application requirements. Actual performance is subject to the Omron's Warranty and Limitations of Liability.

### Change in Specifications.

Product specifications and accessories may be changed at any time based on improvements and other reasons. It is our practice to change part numbers when published ratings or features are changed, or when significant construction changes are made. However, some specifications of the Product may be changed without any notice. When in doubt, special part numbers may be assigned to fix or establish key specifications for your application. Please consult with your Omron's representative at any time to confirm actual specifications of purchased Product.

### Errors and Omissions.

Information presented by Omron Companies has been checked and is believed to be accurate; however, no responsibility is assumed for clerical, typographical or proofreading errors or omissions.

2017.1

In the interest of product improvement, specifications are subject to change without notice.

**OMRON Corporation**  
Industrial Automation Company

<http://www.ia.omron.com/>

(c)Copyright OMRON Corporation 2017 All Right Reserved.